

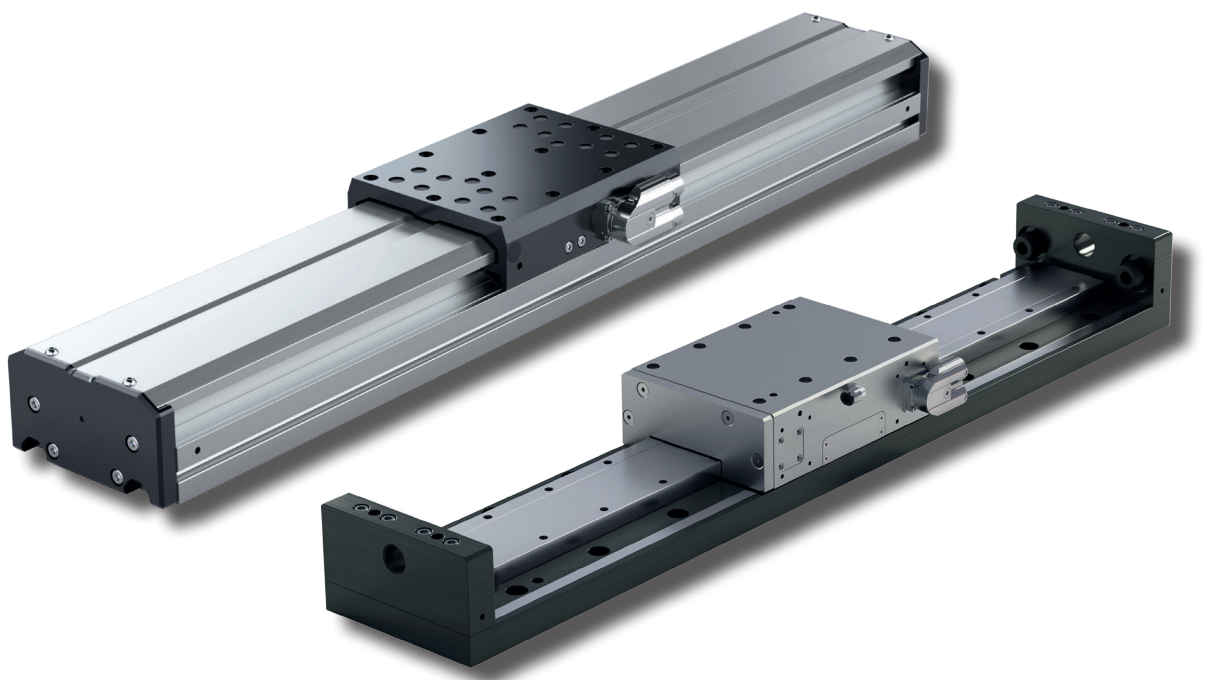

LINEAR AXIS HN & HG



HG/HN

LINEAR MOTOR AXES | HG/HN LINEAR AXIS

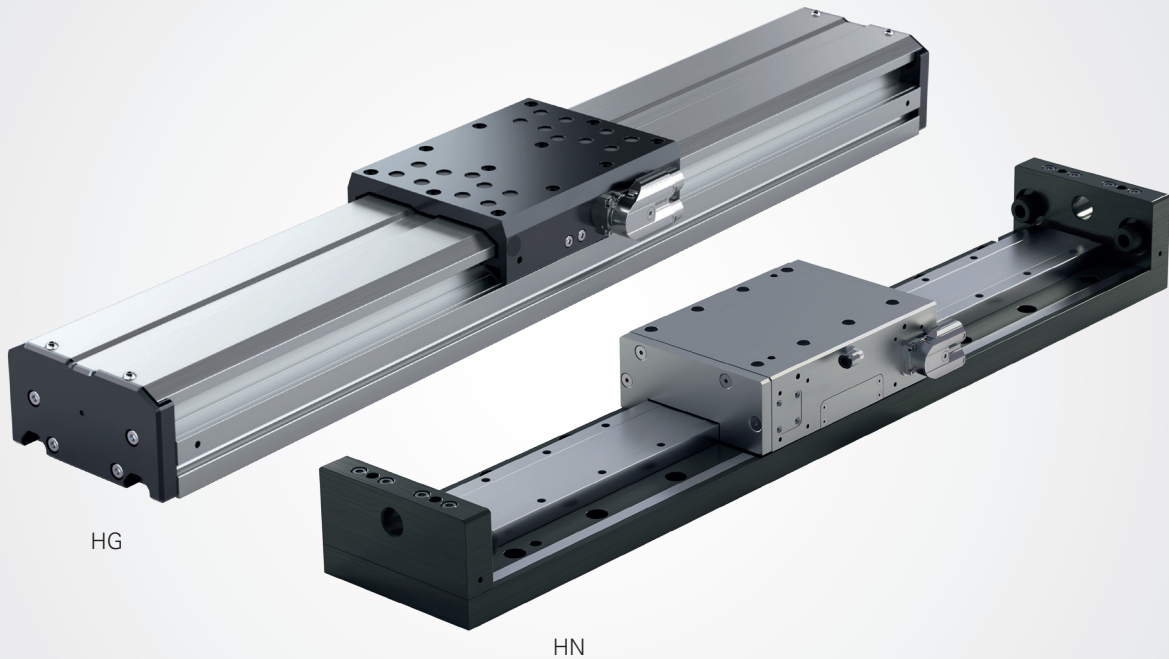

HG/HN LINEAR MOTOR AXES

CERTIFICATION AS UL RECOGNIZED COMPONENT

The WEISS linear motor axes are optionally available in the "UL Recognized" version.



FREELY AND INTUITIVELY PROGRAMMABLE

W.A.S. 2 – WEISS Application Software: secure and fast commissioning with free-of-charge user software.



OKU relies on the perfect combination of HN and HL axes for its ball bearing assembly cell. User-programmable linear motor axes are the ideal choice for extremely fast process movements and strict requirements in terms of both dynamic performance and precision.

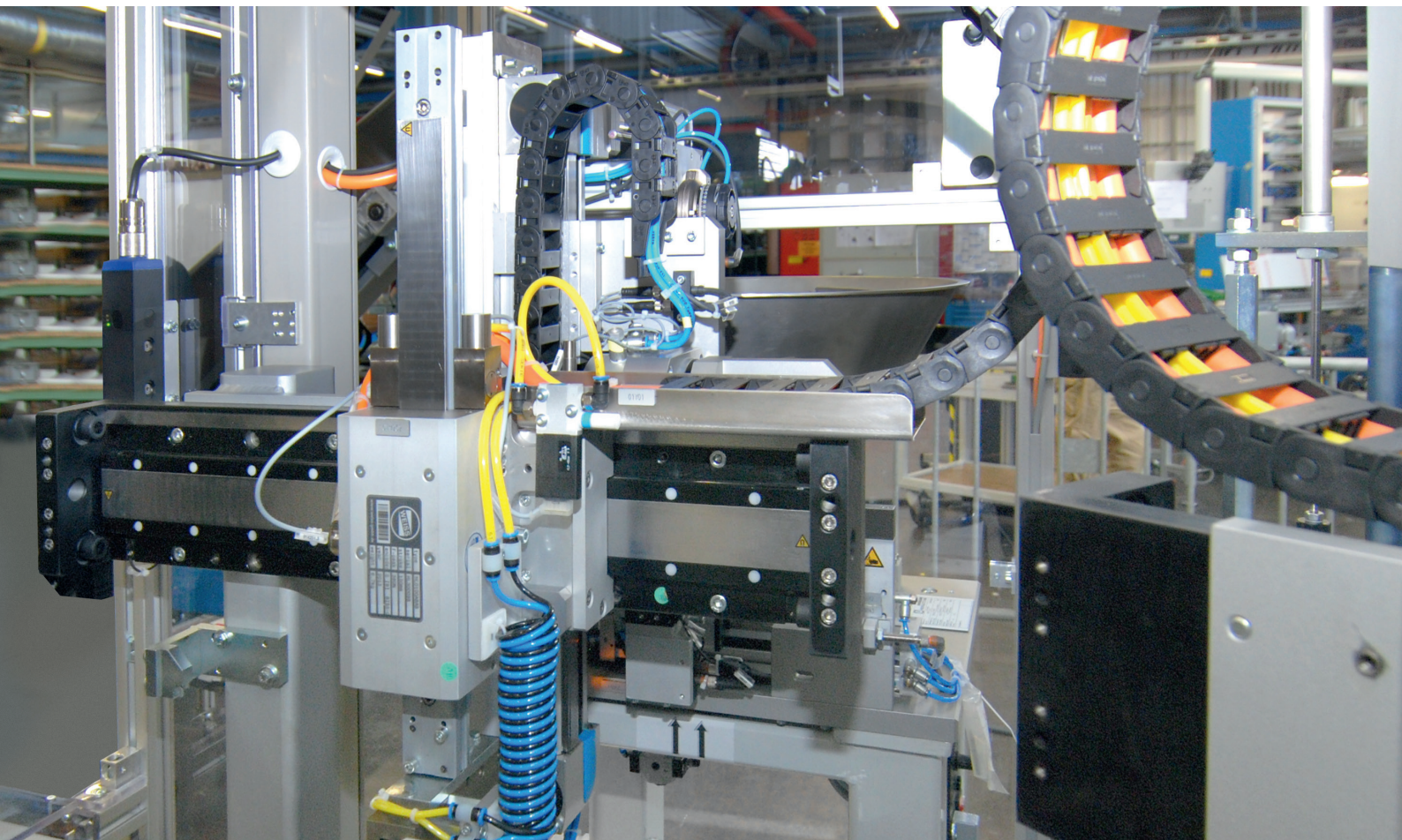

The latest in uncompromising, highly dynamic drive technology for your basic axis. Highly integrated and ready for installation. Compact and precise ball-type linear guides and an absolute measuring system are just as much a part of the concept as the automatic lubrication. The aluminium profile-based HG axes can also be used in areas in which cost factors have typically made conventional drives the standard choice in the past: the most advanced linear technology at extremely attractive conditions. Both versions impress with their smooth movements and maximum dynamics.

ADVANTAGES

- Freely positionable
- Extremely high dynamic performance thanks to direct drive
- Low maintenance costs
- Low energy costs
- Compact design
- Convincing price-quality ratio (particularly in the case of HG axes)
- HN axes with high power density available in many different sizes
- HG axes with covered guide profile with standard attachment options

GENERAL INFORMATION

- The HG model range comes with lifetime lubrication, making maintenance intervals a thing of the past.
- All motors are equipped with overtemperature protection (PTC)
- The installation location of the linear axes can be freely chosen
- Standard with safe encoder mounting (functional safety)

OPTIONS

- The HN linear axes can be equipped with manual or automatic lubrication
- Multiple carriages on a single axis
- Absolute measuring systems
- Optionally as "UL Recognized" version

HG 12A

TECHNICAL DATA

U	Voltage range:	200-480 V _{AC rms}
a_{Max}	Max. acceleration:	40 m/s ²
v_{Max}	Max. speed:	4 m/s
F_{N mot}	Nominal force:	33 N
F_{P mot}	Peak force:	102 N
I_P	Peak current:	2 A
	Temperature monitoring:	PTC
s_{Max}	Max. stroke:	bis 1000 mm in 100 mm
	Repeat accuracy:	0.005 mm*
m_{rec}	Max. recommended load:	5 kg
m_{gui 0}	Mass of the guide rail with 0 mm stroke:	1.44 kg
m_{gui 100}	Mass of the guide rail per 100 mm stroke:	0.72 kg
m_{carr}	Mass of the carriage with motor:	1.45 kg

* Depends on the application and environmental conditions.

LOAD DATA (static)

M_{X stat}	Max. static moment about the X-axis:	150 Nm
M_{Y stat}	Max. static moment about the Y-axis:	40 Nm
M_{Z stat}	Max. static moment about the Z-axis:	150 Nm
F_{X stat}	Max. static force in the X-axis:	150 N
F_{Z stat}	Max. static force in the Z-axis:	300 N

LOAD DATA (dynamic)

M_{X dyn}	Max. dynamic moment about the X-axis:	20 Nm
M_{Y dyn}	Max. dynamic moment about the Y-axis:	8 Nm
M_{Z dyn}	Max. dynamic moment about the Z-axis:	20 Nm
F_{X dyn}	Max. dynamic force in the X-axis:	100 N
F_{Z dyn}	Max. dynamic force in the Z-axis:	150 N

ENCODER

Balluff	sin/cos
Balluff	BISS
Balluff	SSI

LOAD DATA

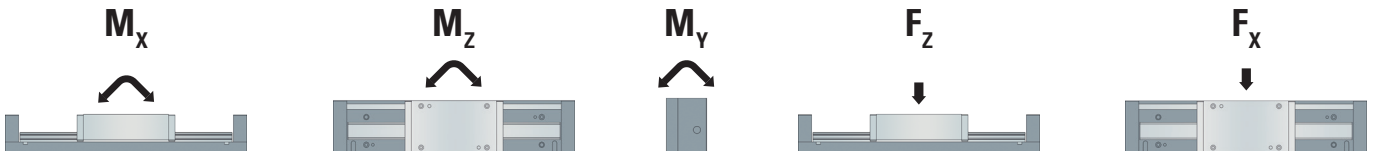

TIMING DIAGRAM

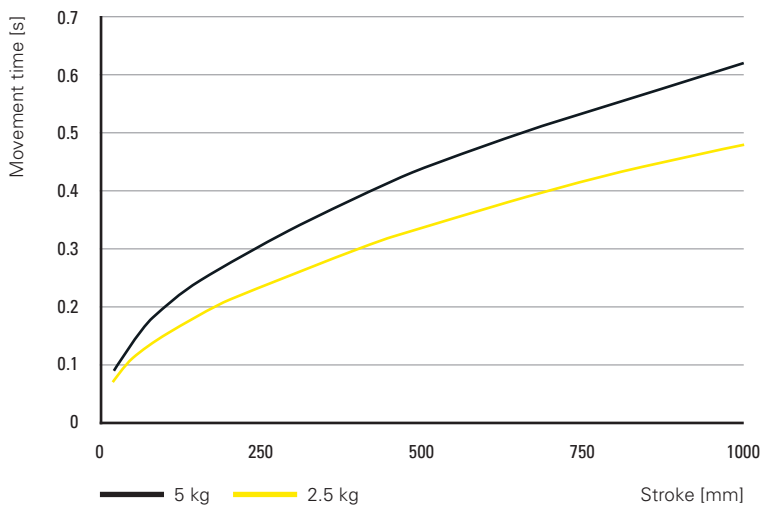

HG 25A

TECHNICAL DATA

U	Voltage range:	200-480 V _{AC rms}
a_{Max}	Max. acceleration:	40 m/s ²
v_{Max}	Max. speed:	4 m/s
F_{N mot}	Nominal force:	65 N
F_{P mot}	Peak force:	180 N
I_P	Peak current:	6 A
	Temperature monitoring:	PTC
s_{Max}	Max. stroke:	bis 1000 mm in 100 mm
	Repeat accuracy:	0.005 mm*
m_{rec}	Max. recommended load:	10 kg
m_{gui 0}	Mass of the guide rail with 0 mm stroke:	2.24 kg
m_{gui 100}	Mass of the guide rail per 100 mm stroke:	1 kg
m_{carr}	Mass of the carriage with motor:	2.05 kg

* Depends on the application and environmental conditions.

LOAD DATA (static)

M_{X stat}	Max. static moment about the X-axis:	200 Nm
M_{Y stat}	Max. static moment about the Y-axis:	100 Nm
M_{Z stat}	Max. static moment about the Z-axis:	200 Nm
F_{X stat}	Max. static force in the X-axis:	250 N
F_{Z stat}	Max. static force in the Z-axis:	500 N

LOAD DATA (dynamic)

M_{X dyn}	Max. dynamic moment about the X-axis:	30 Nm
M_{Y dyn}	Max. dynamic moment about the Y-axis:	15 Nm
M_{Z dyn}	Max. dynamic moment about the Z-axis:	30 Nm
F_{X dyn}	Max. dynamic force in the X-axis:	150 N
F_{Z dyn}	Max. dynamic force in the Z-axis:	200 N

ENCODER

Balluff	sin/cos
Balluff	BISS
Balluff	SSI

LOAD DATA

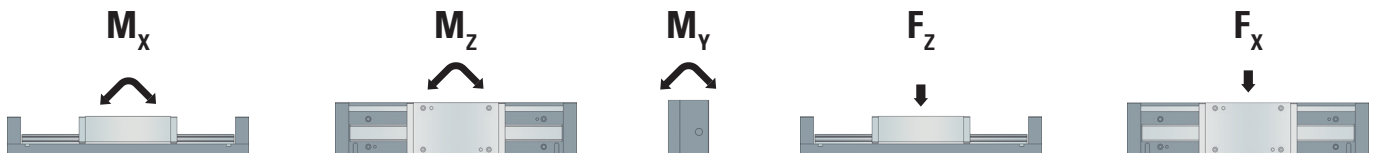

TIMING DIAGRAM

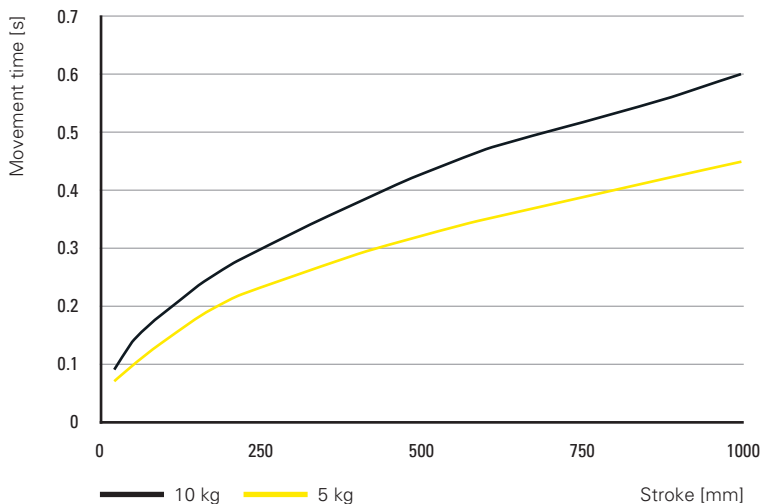

DIMENSIONS

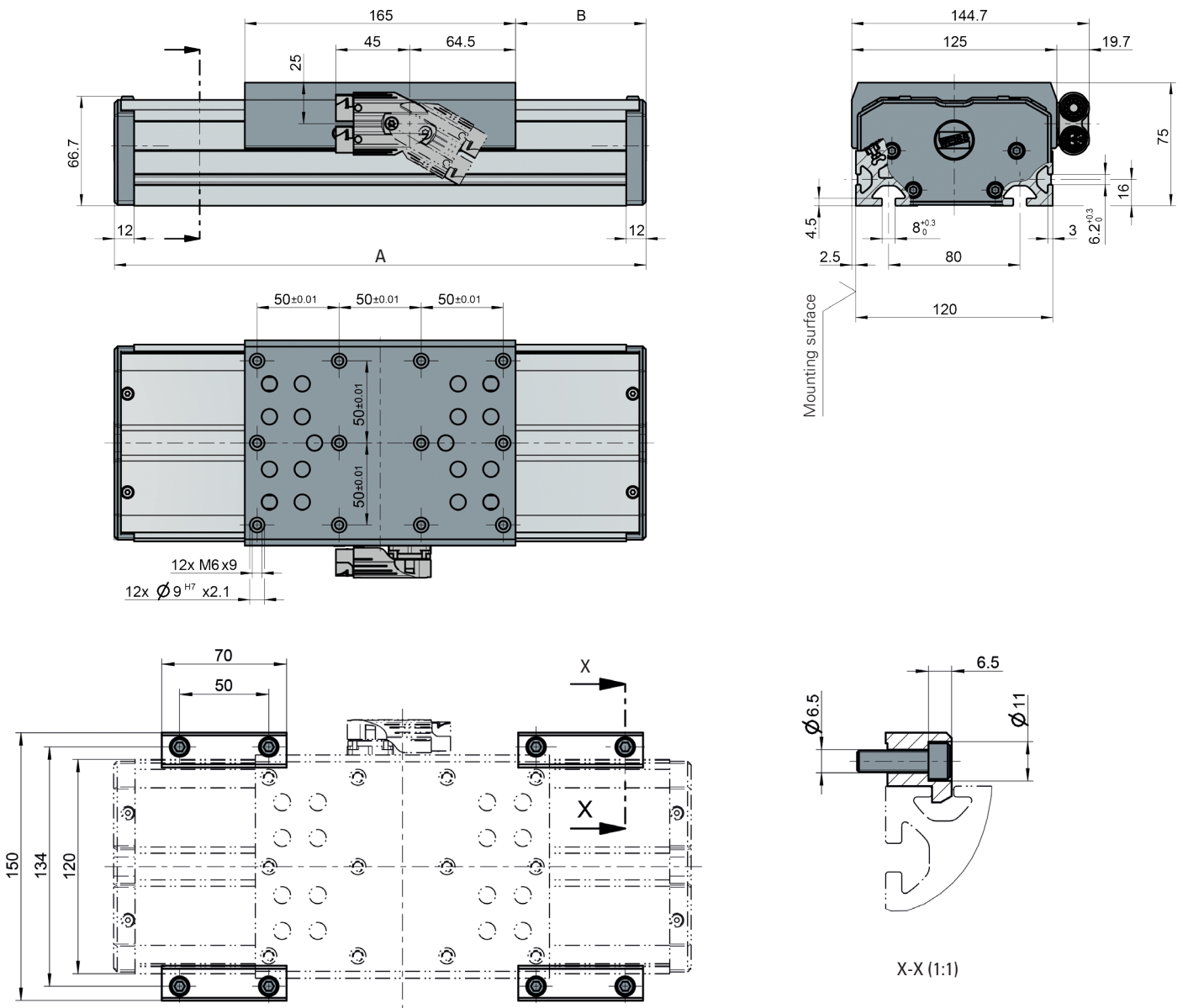

Standardhöhe	A
100	324
200	424
300	524
400	624
500	724
600	824
700	924
800	1024
900	1124
1000	1224

Attention: Rubber buffers (30mm) are installed on both sides. However, the useful stroke remains unchanged.

STANDARD FEATURES: COVER, SAFE ENCODER MOUNTING, LIFETIME LUBRICATION, BASE PLATE ALUMINIUM NATURAL AMODIZED, SINGLE SLIDE BLACK ANODIZED, CENTERING SLEEVES INCLUDED, MOUNTING MATERIAL MUST BE ORDERED SEPARATELY

Attribute	Value	HG25	300	BISS20
Type	HG12 HG25			
Stroke in mm	100 bis 1000 in 100mm Schritten			
Measuring system	SICO1 = magnetic, incremental SSI20B = magnetic, absolute SSI 20Bit (Bosch) SSI20S = magnetic, absolute SSI 20Bit (Siemens) BISS20 = magnetic, absolute BiSS 20Bit (B&R)			

HN 100

TECHNICAL DATA

U	Voltage range:	200-480 V _{AC rms}
a_{Max}	Max. acceleration:	40 m/s ²
v_{Max}	Max. speed:	4 m/s *
F_{N mot}	Nominal force:	150 N
F_{P mot}	Peak force:	380 N
I_P	Peak current:	9.5 A
s_{Max}	Max. stroke:	bis 1000 mm in 100 mm; > 1000 mm auf Anfrage
	Repeat accuracy:	0.005 mm**
m_{rec}	Max. recommended load:	25 kg
m_{gui 0}	Mass of the guide rail with 0 mm stroke:	5.59 kg (Alu)
m_{gui 100}	Mass of the guide rail per 100 mm stroke:	1.61 kg (Alu)
m_{carr}	Mass of the carriage with motor:	4.7 kg (Alu)

*In combination with W.A.S. 2 compact the maximum speed is 3 m/s.
** Depends on the application and environmental conditions.

LOAD DATA (static)

M_{X stat}	Max. static moment about the X-axis:	350 Nm
M_{Y stat}	Max. static moment about the Y-axis:	100 Nm
M_{Z stat}	Max. static moment about the Z-axis:	350 Nm
F_{X stat}	Max. static force in the X-axis:	500 N
F_{Z stat}	Max. static force in the Z-axis:	750 N

LOAD DATA (dynamic)

M_{X dyn}	Max. dynamic moment about the X-axis:	40 Nm
M_{Y dyn}	Max. dynamic moment about the Y-axis:	15 Nm
M_{Z dyn}	Max. dynamic moment about the Z-axis:	40 Nm
F_{X dyn}	Max. dynamic force in the X-axis:	150 N
F_{Z dyn}	Max. dynamic force in the Z-axis:	150 N

ENCODER

Balluff	sin/cos
Balluff	BISS
Balluff	SSI

LOAD DATA

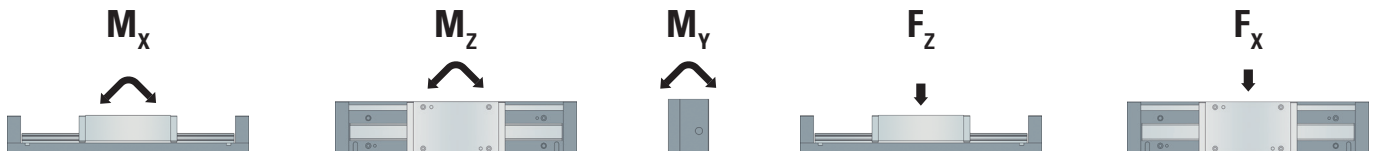

TIMING DIAGRAM

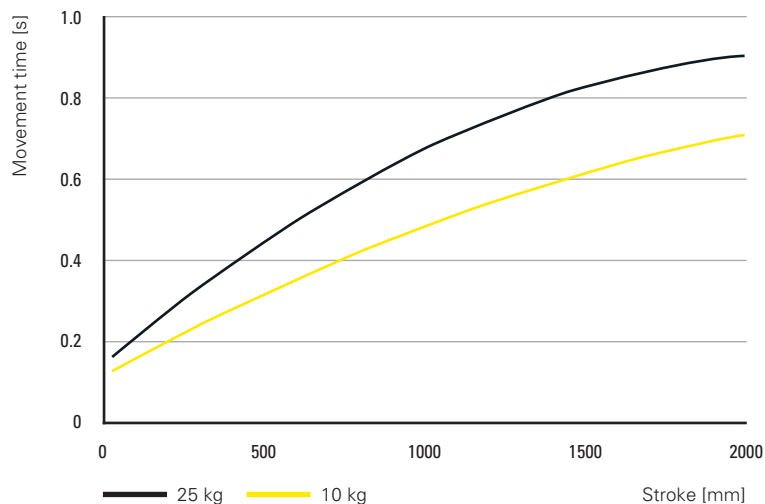

DIMENSIONS

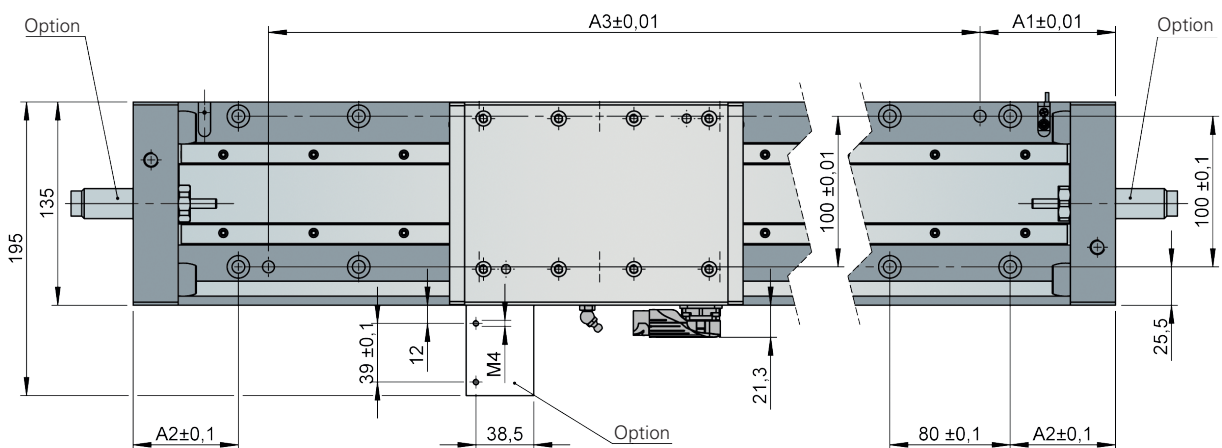
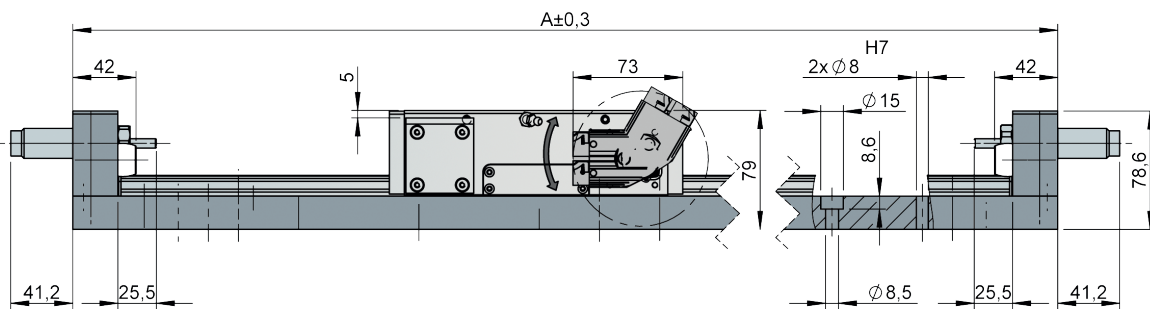
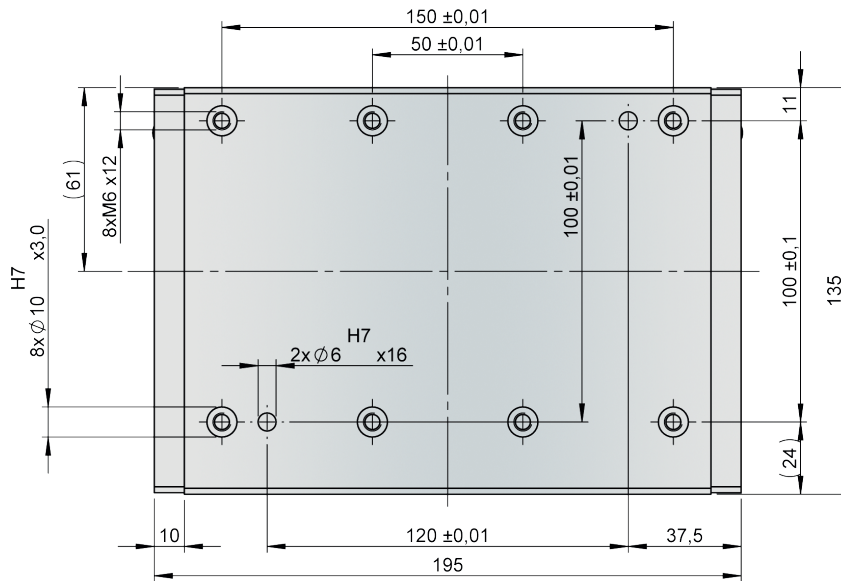

Standard strokes (Examples)	A	A1	A2	A3
500	780	90	70	600
1000	1280	140	80	1000

Strokes larger than 1000 mm and intermediate strokes in 100 mm increments available on request

HN 200

TECHNICAL DATA

U	Voltage range:	200-480 V _{AC rms}
a_{Max}	Max. acceleration:	40 m/s ²
v_{Max}	Max. speed:	4 m/s
F_{N mot}	Nominal force:	250 N
F_{P mot}	Peak force:	700 N
I_P	Peak current:	11.2 A
s_{Max}	Max. stroke:	bis 1000 mm in 100 mm; > 1000 mm auf Anfrage
	Repeat accuracy:	0.005 mm
m_{rec}	Max. recommended load:	50 kg
m_{gui 0}	Mass of the guide rail with 0 mm stroke:	9.59 kg (Alu)
m_{gui 100}	Mass of the guide rail per 100 mm stroke:	2.22 kg (Alu)
m_{carr}	Mass of the carriage with motor:	8.1 kg (Alu)

* Depends on the application and environmental conditions.

LOAD DATA (static)

M_{X stat}	Max. static moment about the X-axis:	500 Nm
M_{Y stat}	Max. static moment about the Y-axis:	200 Nm
M_{Z stat}	Max. static moment about the Z-axis:	500 Nm
F_{X stat}	Max. static force in the X-axis:	750 N
F_{Z stat}	Max. static force in the Z-axis:	1000 N

LOAD DATA (dynamic)

M_{X dyn}	Max. dynamic moment about the X-axis:	80 Nm
M_{Y dyn}	Max. dynamic moment about the Y-axis:	40 Nm
M_{Z dyn}	Max. dynamic moment about the Z-axis:	80 Nm
F_{X dyn}	Max. dynamic force in the X-axis:	250 N
F_{Z dyn}	Max. dynamic force in the Z-axis:	500 N

ENCODER

Balluff	sin/cos
Balluff	BISS
Balluff	SSI

LOAD DATA

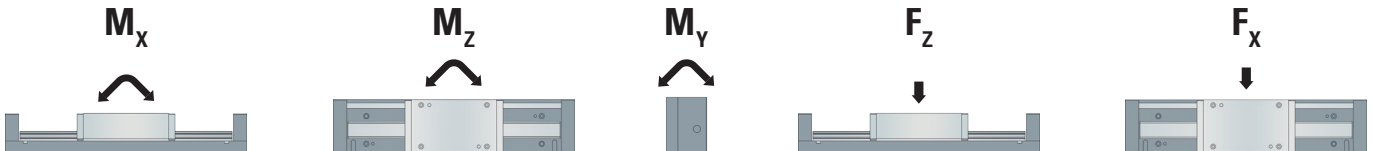

TIMING DIAGRAM

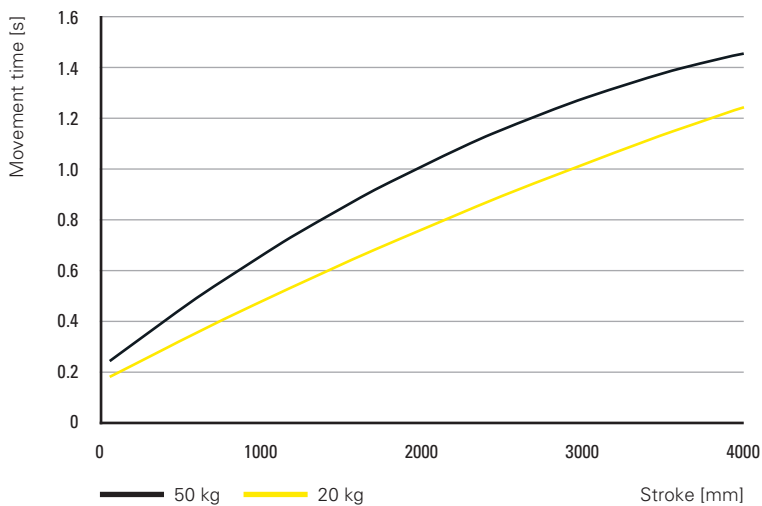

HN 400

TECHNICAL DATA

U	Voltage range:	200-480 V _{AC rms}
a_{Max}	Max. acceleration:	40 m/s ²
v_{Max}	Max. speed:	4 m/s
F_{N mot}	Nominal force:	500 N
F_{P mot}	Peak force:	1400 N
I_P	Peak current:	18 A
s_{Max}	Max. stroke:	bis 1000 mm in 100 mm; > 1000 mm auf Anfrage
	Repeat accuracy:	0.005 mm
m_{rec}	Max. recommended load:	100 kg
m_{gui 0}	Mass of the guide rail with 0 mm stroke:	15.11 kg (Alu)
m_{gui 100}	Mass of the guide rail per 100 mm stroke:	2.9 kg (Alu)
m_{carr}	Mass of the carriage with motor:	13.4 kg (Alu)

* Depends on the application and environmental conditions.

LOAD DATA (static)

M_{X stat}	Max. static moment about the X-axis:	1000 Nm
M_{Y stat}	Max. static moment about the Y-axis:	500 Nm
M_{Z stat}	Max. static moment about the Z-axis:	1000 Nm
F_{X stat}	Max. static force in the X-axis:	1000 N
F_{Z stat}	Max. static force in the Z-axis:	1500 N

LOAD DATA (dynamic)

M_{X dyn}	Max. dynamic moment about the X-axis:	140 Nm
M_{Y dyn}	Max. dynamic moment about the Y-axis:	60 Nm
M_{Z dyn}	Max. dynamic moment about the Z-axis:	140 Nm
F_{X dyn}	Max. dynamic force in the X-axis:	500 N
F_{Z dyn}	Max. dynamic force in the Z-axis:	1000 N

ENCODER

Balluff	sin/cos
Balluff	BISS
Balluff	SSI

LOAD DATA

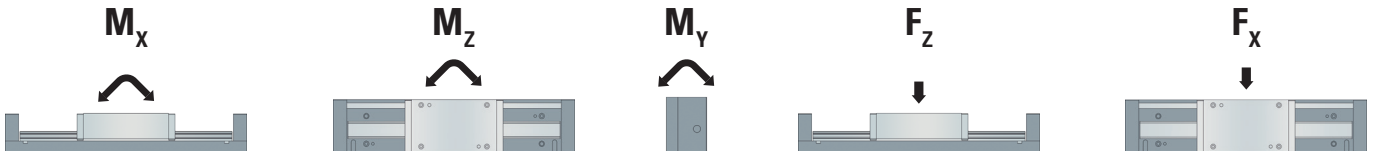

TIMING DIAGRAM

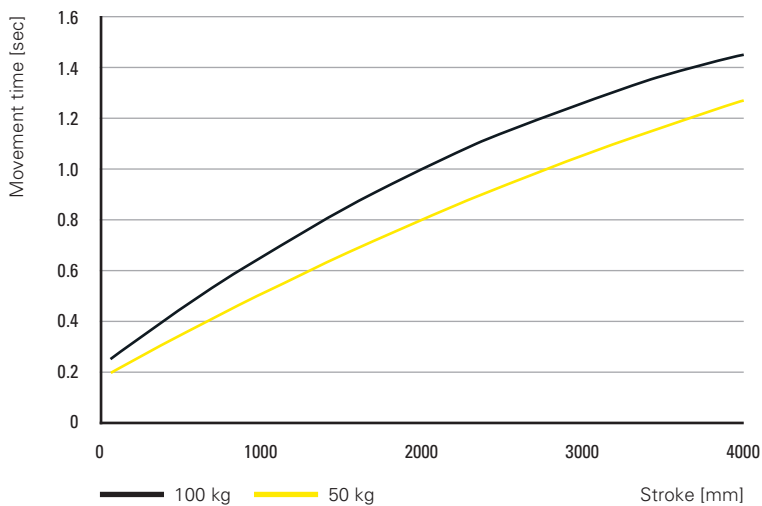

DIMENSIONS

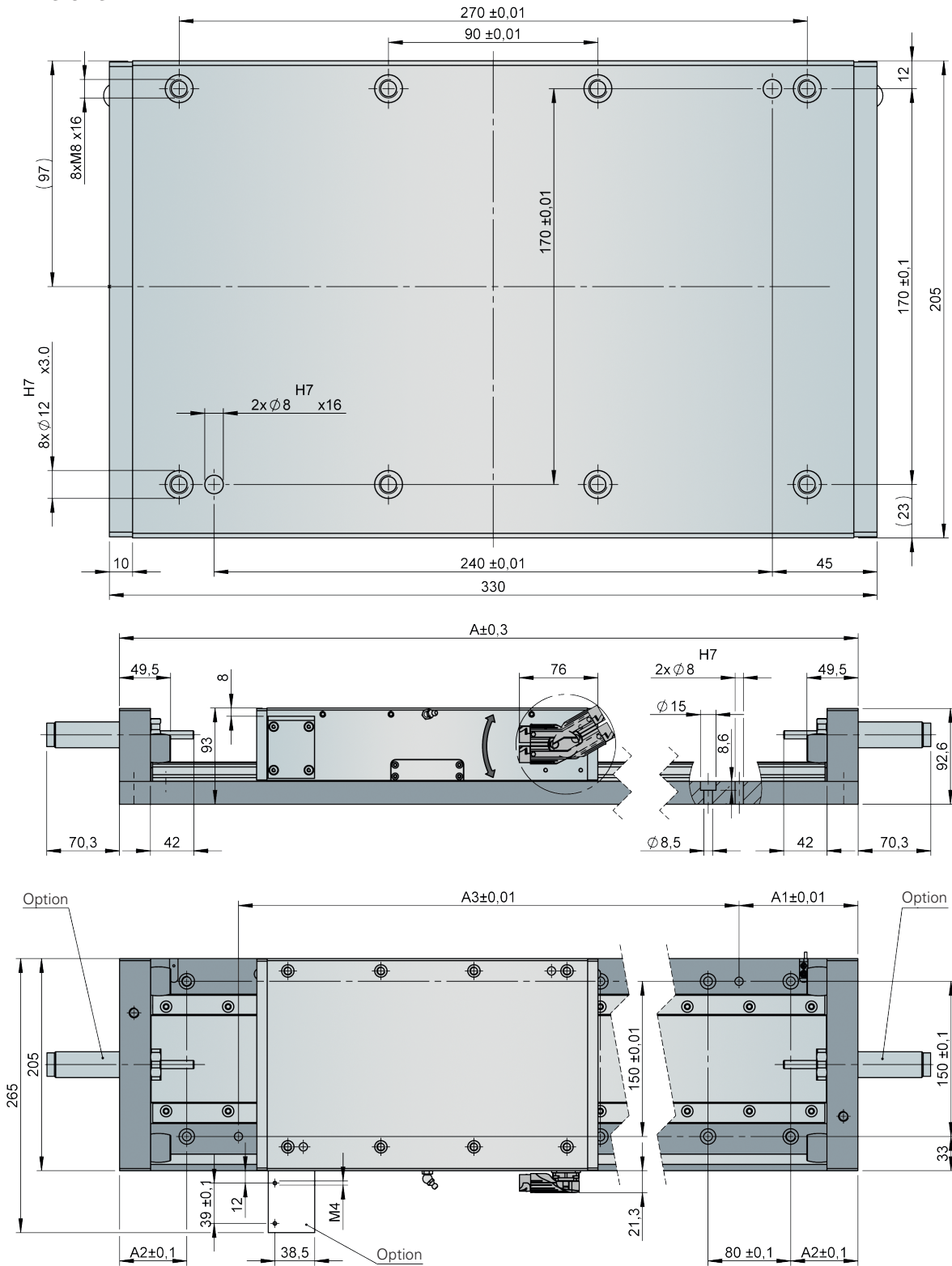

Standard strokes (Examples)	A	A1	A2	A3
500	930	115	65	700
1000	1430	115	75	1200

Strokes larger than 1000 mm and intermediate strokes in 100 mm increments available on request

STANDARD FEATURES: SAFE ENCODER MOUNTING, ALUMINIUM BASE PLATE, REFERENCE SWITCH ON THE RIGHT (ONLY FOR SIC01), SINGLE SLIDE, RUBBER END BUFFER, LUBRICATION CONNECTION FOR MANUAL LUBRICATION MOUNTED, PLUG-IN CONNECTION FOR AUTOMATIC LUBRICATION AND CENTERING SLEEVES ENCLOSED

Attribute	Value	HN100	500	SIC01	PL
Type	HN100 HN200 HN400				
Stroke in mm	100 to 2000 in 100mm steps				
Measuring system	SIC01 = magnetic, inkremental SSI20B = magnetic, absolute SSI 20Bit (Bosch), up to stroke 1000 BISS20 = magnetic, absolute BiSS 20Bit (B&R), up to stroke 1000 SSI20S = magnetic, absolute SSI 20Bit (Siemens), up to stroke 1000 SSI23B = magnetic, absolute SSI 23Bit (Bosch), from stroke >1000 SSI23S = magnetic, absolute SSI 23Bit (Siemens), from stroke >1000 BISS32 = magnetic, absolute BiSS 32Bit (B&R), from stroke >1000				
Connector position	PL = connector left PR = connector right				



INSPIRING PEOPLE **GREAT SOLUTIONS**

WEISS GMBH

Siemensstrasse 17 74722 Buchen Germany
Phone +49 6281 5208-0 Fax +49 6281 5208-99
info@weiss-world.com
www.weiss-world.com

Disclaimer

The WEISS product catalogue has been compiled with the greatest of care. Nonetheless, the details given are only for non-binding general information and do not replace in-depth individual consulting for a purchase decision. WEISS GmbH assumes no liability for the correctness, completeness, quality of the information provided nor that it is up to date. Liability for material defects and deficiencies in title pertaining to the information, in particular for its correctness, freedom from third-party intellectual property rights, completeness and usability is excluded – except in cases of intent or fraud. WEISS GmbH shall be freed from all other liability, unless it is mandatorily liable pursuant to the German Product Liability Law for intentional or fraudulent action or for a breach of significant contractual duties. Liability due to a breach of significant contractual duties is restricted to typical, foreseeable damages – except in cases of intent or gross negligence

Copyright

© WEISS GmbH, Buchen, Germany. All rights reserved. All content such as texts, images and graphics, as well as arrangements thereof, are subject to protection by copyright and other laws on the protection of intellectual property. Content of this catalogue may not be copied, distributed or changed for commercial purposes. Some content is further subject to third-party copyright. The intellectual property is protected by various laws such as the industrial property rights, trademark rights, and copyright of WEISS GmbH.